

Ancasta
RACE BOATS



HYS
HAMBLE YACHT SERVICES

ADVANCED RIGGING & HYDRAULICS

GP

McCONAGHY

MC38
GRAND PRIX

2015 Circuit



Ancasta
RACE BOATS



HYS
HAMBLE YACHT SERVICES

**ADVANCED
RIGGING
& HYDRAULICS**

GP

McCONAGHY



MC38
GRAND PRIX

Specs

- LOA 13.5m
- Displacement 3200kg
- Lead bulb 1,600 kg
- Crew weight 650 kg
- Draft 2.8m
- Carbon/E-Glass/corecell construction,
- Autoclaved prepreg carbon keel fin and rudder
- 2 piece carbon mast with carbon standing rigging.

www.ancasta.com/MC38GP

The circuit

A new approach to Solent racing, using the MC38 One Design with an annual series of 6 events all based in UK waters. It is set to be *FUN, FAST, COMPETITIVE* racing back in the Solent with incentivised racing for series champions.



Six events per year

- | | |
|---------------------|--------------------------------|
| 1. GP Season opener | 25-26th April |
| 2. GP Event | 16-17th May |
| 3. RTIR GP | 26-27th June |
| 4. GP Event | 11-12th July |
| 5. Cowes week | 8-11th Aug Dual scoring IRC/OD |
| 6. GP Championships | 4-6th Sept |



GP Event home & Service centre

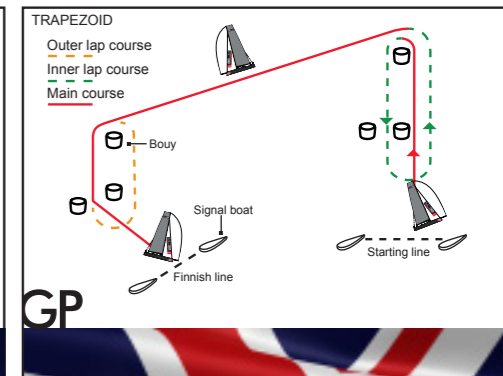
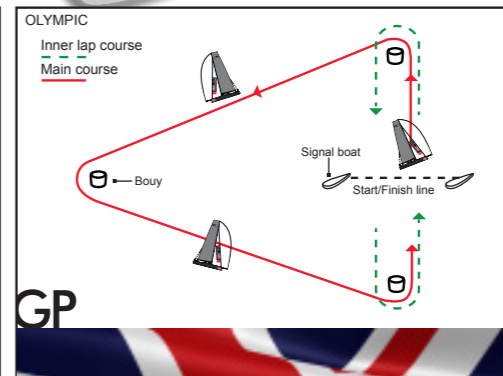
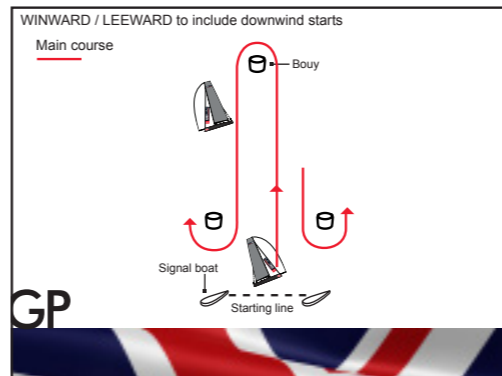
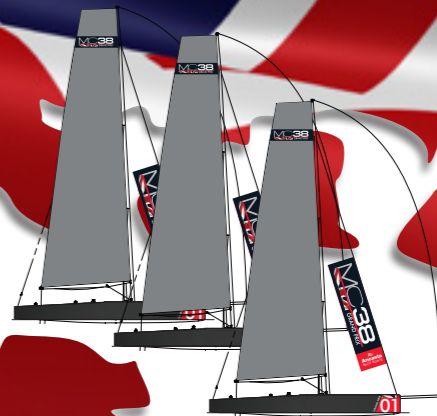

Class Membership

- One Design performance racing run under strict MC38 Class rules – V1.4, 2014.
- A new and varied format for exciting Solent racing in 2015.
- Utilising a structured platform, with centralised administration and race management to ensure racing is of the highest quality whilst maintaining a strict eye on capital expenditure.
- Limitations on new sails and numbers of professional crew are implemented in order to create budget caps and reduce the arms race effect.
- A 2-tier membership approach to cater for all owners requirements.
- Highly professional race management service
- Designated events and media centre for briefings and post-race analysis.



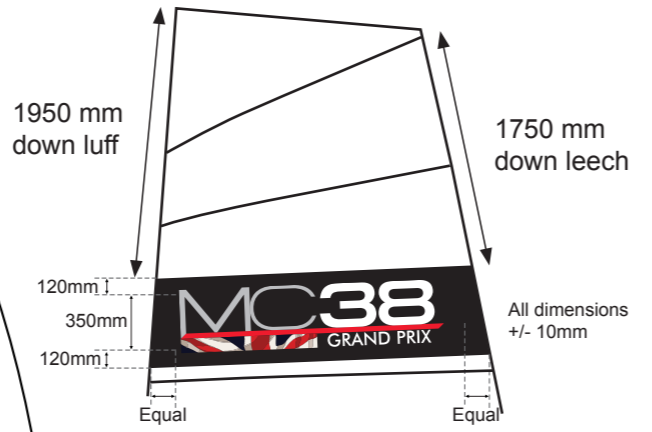

Boat branding

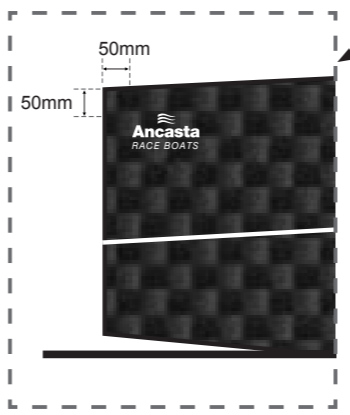
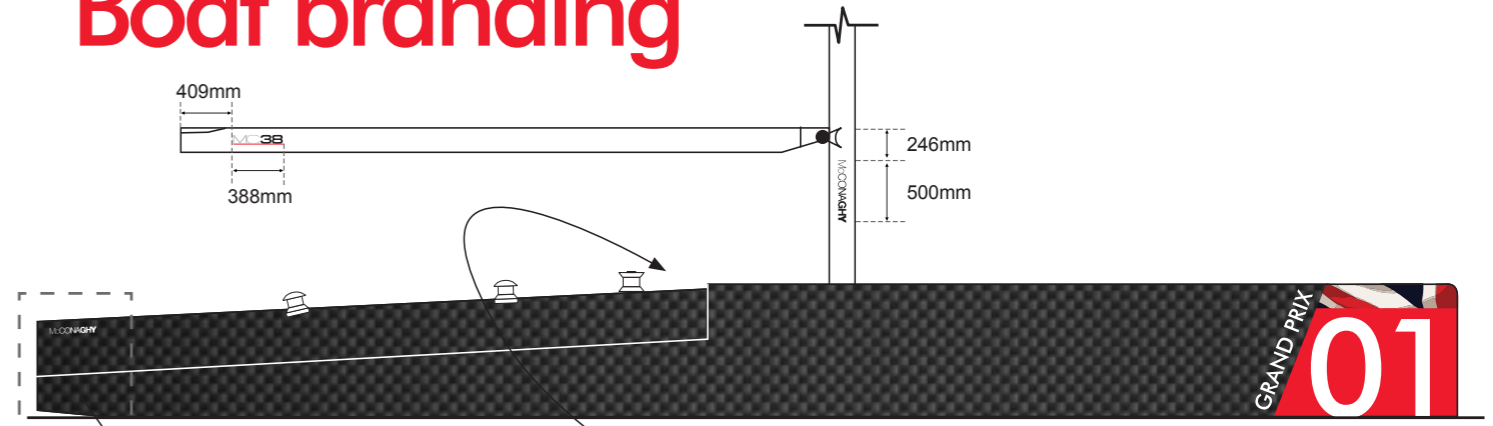

COCKPIT SIDE DETAIL



TOPSIDE DETAIL

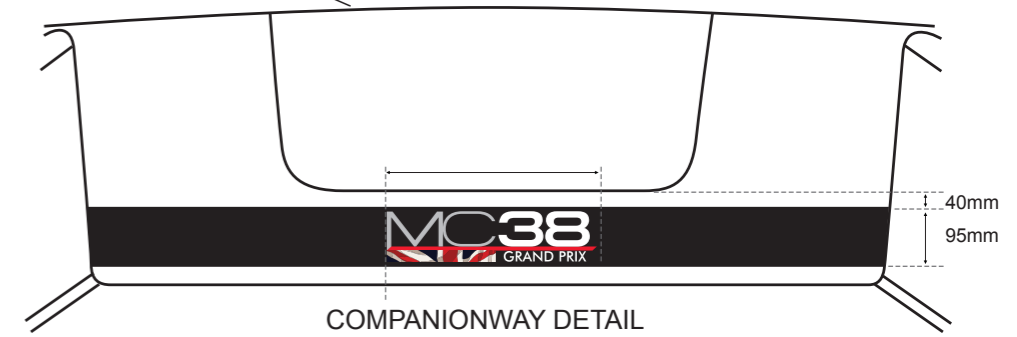

COMPANIONWAY DETAIL



Price breakdown

	Unit price £	Quantity	Line Price
MC 38 Base boat price as per standard specification	£166,026.00	1	£166,026.00
Options:			
Tack Tick integrated wireless system supplied and installed, see detailed spec	£6,346.50		
B&G Hydra electronics package supplied and installed, see detailed spec	£6,538.46		
B&G H5000 package supplied and installed with 20/20 displays	£10,897.44	1	£10,897.44
Silva magnetic compass	£192.31	1	£192.31
VHF radio inc aerial	£352.56	1	£352.56
20/20 Mast bracket	£1,987.18	1	£1,987.18
*Porta potti marine toilet	£243.59		
*Pipecots (removeable for OD) x4	£1,919.87		
*Stove and galley unit (removable for OD)	£333.33		
*Freshwater system 2x 50L bladders 1x hand pump	£310.90		
*Cockpit clipping points 2x harken folding padeyes	£80.13		
*Hella marine navigation lights mounted intermediate lifeline level	£291.67	1	£291.67
* Padeyes for liferaft	£160.22		
Bilge pump (2nd below deck)	£185.90	1	£185.90

...continued	Unit price £	Quantity	Line Price
Antifouling - below water line	£2,820.51		
	£1,275.64		
Change in hull standard gelcoat colour	£1,275.64		
Custom graphics	P.O.A.		
Cove line or boat stripe (standard gelcoat colour)	£769.23		
McConaghy twin carbon wheels and steering system	£5,769.23		
Primary winch upgrade to self tailing	£355.77		
Primary winch upgrade to Harken quattro ST	£641.03	1	£641.03
Dock box large L 3460 x W 390 x H 685mm	£480.77		
Dock box small L 2455 x W 440 x H 515mm	£346.15		
Commissioning	P.O.A.		
Galvanised hardstand & deck cargo shipping cradle	£7,660.26		
Steel frame and ratchet strap packaging for shipping hull within 40Ft open top container	£4,006.41		
Hull support splashes for mounting on your cradle	£1,538.46		
Shrink wrap for transport	£929.49	1	£929.49
Multipurpose cradle	£9,134.62	1	£9,134.62
Dry sailing contract from HYS - 12 months	£6,712		
Shipment from McConaghy factory china to Hamble Yacht Services. Ex Taxes	£13,000.00	1	£13,000.00
Suit of sail by North (3Di, 3 Jibs, 2 Kites)	£51,079.35		
Suit of sails by North (3DL, 3 jibs, 2 Kites)	£43,432		

£203,638 Ex Vat

*Compliant with CAT4 ORC safety requirements

Membership fees

TIER ONE - Circuit

Total capital required upon 4 teams committing to the 6 event circuit.

Administration; Class rules, MC38 GP Class measurement & certification, Owners handbook, results documentation.	£980
Race management; Race documentation, Race officials, committee boat and mark laying cover, protest committee, regatta fuel.	£27,120
Media coverage; Pre and post event press releases, regatta reports, social media updates, full event branding and on the water tracking system.	£7,760
Insurance; Public liability.	£800
Circuit provisioning; Purchase of racing marks and ground tackle, buoy branding, construction of designated events centre, circuit re-investment.	£3,340
	<u>Total circuit expenditure</u> £40,000
Based on 4 teams. As class continues to grow, capital cost will reduce per team.	<u>Cost per Team</u> £10,000

TIER TWO - Circuit & Maintenance

Outlined for individual teams.

Circuit fee (as per TIER ONE)	£10,000
Boat management; launch/recovery overseeing, acid washes, interior and exterior valet, sail removal.	£1,200
Boat maintenance/servicing; 4 days work per month to complete required jobs list and 2 full hardware services per season.	£5,200
Crew management; organise crew for training and events schedule.	£600
Logistics; food/drink provisioning, sail preparation and safety checks.	£1,200
Winterisation; full decommission of boat, engine winterisation, sails stored, rig removal and service, hardware checks.	£600
Storage; use of MC38 Class temperature controlled container for equipment, immediate access to class stock of spares available at cost price.	£200
	<u>Total expenditure</u> £19,000

What we need from you

- For the class to succeed we need commitment, which in turn will lead to momentum.
- To join the MC38 Grand Prix, payment of a holding deposit of £10,000 must be made to secure a build slot.
- Completion of MC38 Heads of Terms paperwork.
- Once 4 deposits are received, final contracts will be drawn up, at which point the deposit will become part payment and the balance of the deposit will become due.



CONTACT

Class Director – Sam Pearson
Class Secretary – Lou Waldegrave
Graphic Designer – Richard Ford
Marketing – Will Blair
Fleet Director – Bryan Davies

+44 (0)2380 450 000
MC38GP@ancasta.com
www.ancasta.com/MC38GP

